

RoHS  For AC Signal Only

Chip Common Mode Filter (MCM1012B Series) Engineering Specification

■ PRODUCT DETAILS

Part No.	Imp. Com. (Ω) \pm 25% @100MHz	DCR Max. (Ω)	Rated Current Max.(mA)	Rated Voltage (V)	Withstand Voltage (V)	Insulation Resistance Min.(M Ω)
MCM1012B330FB_	33	0.50	300	10	25	200
MCM1012B670FB_	67	0.50	300	10	25	200
MCM1012B900FB_	90	0.60	300	10	25	200
MCM1012B121FB_	120	0.60	300	10	25	200
Test Instruments	<ul style="list-style-type: none"> •HP4291B RF IMPEDANCE / MATERIAL ANALYZER •HP4338A/B MILLIOHMMETER •Agilent 8720ES S-PARAMETER NETWORK ANALYZER •HP6632B SYSTEM DC POWER SUPPLY •Keithley 2410 1100V SOURCE METER 					

** For special part number which is not shown in the above table, please refer to appendix.

■ PART NUMBER CODE

MCM 1012 B 90 0 F B P
1 2 3 4 5 6 7 8

- 1 Series Name
- 2 Size Code: the first two digitals : width(mm), the last two digitals : length(mm)
- 3 Material Code
- 4 Impedance(Ω) \pm 25% (ex : 900=90 Ω ; 121=120 Ω)
- 5 Fixed Decimal Point
- 6 Rated Current Code

A=50mA	B=80mA	C=100mA	D=150mA	E=200mA	F=300mA
G=400mA	H=500mA	I=600mA	J=700mA	K=800mA	

- 7 Soldering: Green Parts: A— Soldering Lead-Free B— Lead-Free for whole chip
- 8 Packaging: P – Embossed paper tape, 7”reel.

■ IMPEDANCE VS. FREQUENCY CHARACTERISTICS

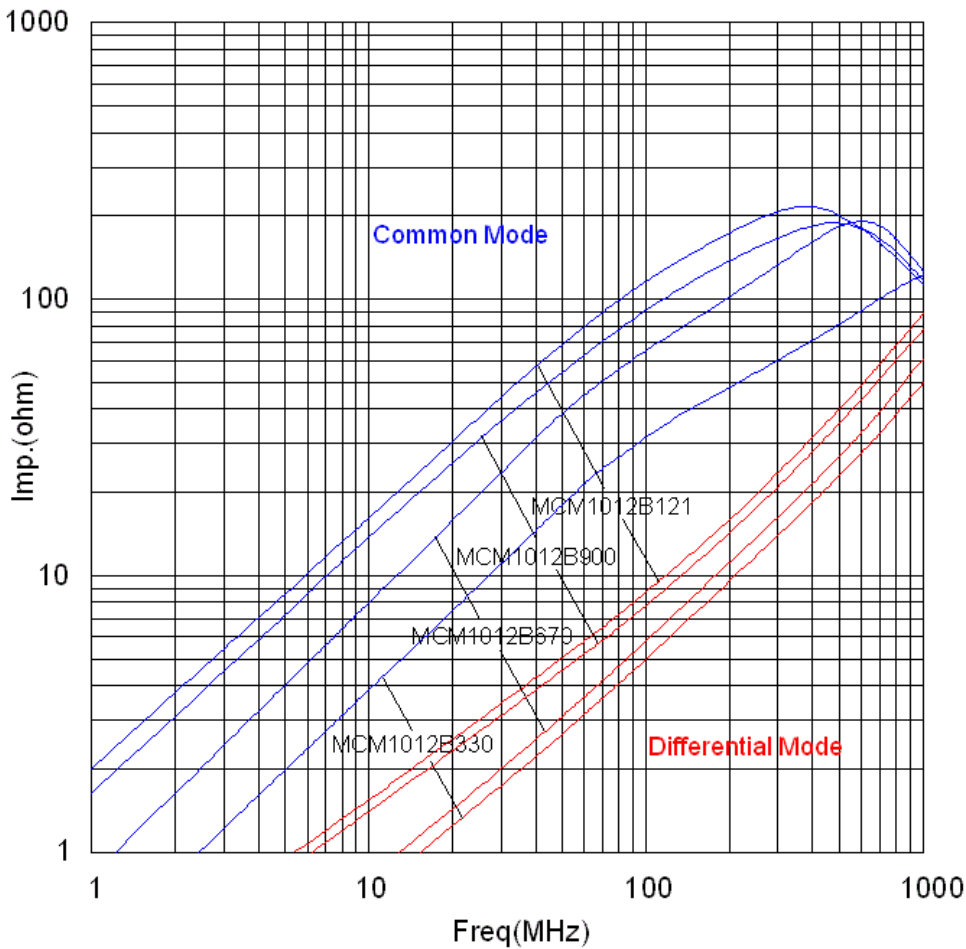

■ SHAPES AND DIMENSIONS

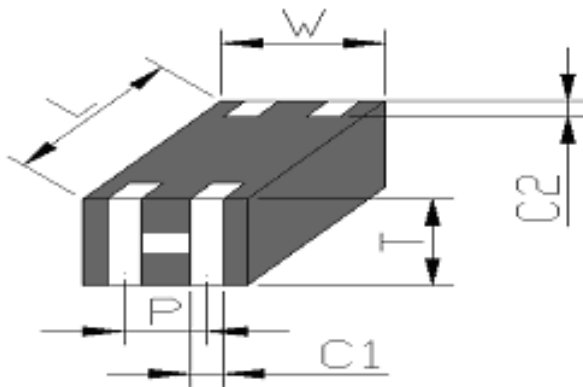

TYPE	1012
L	1.25±0.10
W	1.00±0.10
T	0.82±0.10
P	0.50±0.10
C1	0.30±0.10
C2	0.20±0.15
Unit: mm	

■ MEASURING CIRCUITS

(A):Common mode

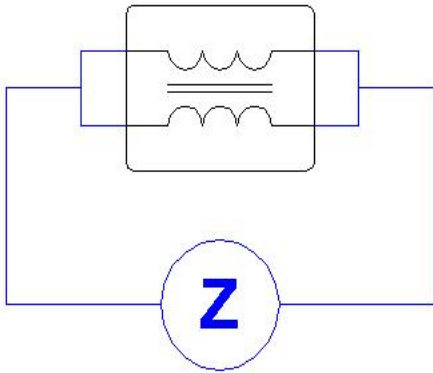

(B):Differential mode

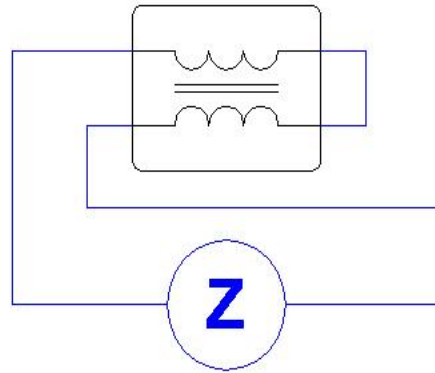

■ CIRCUIT CONFIGURATION & LAYOUT PAD

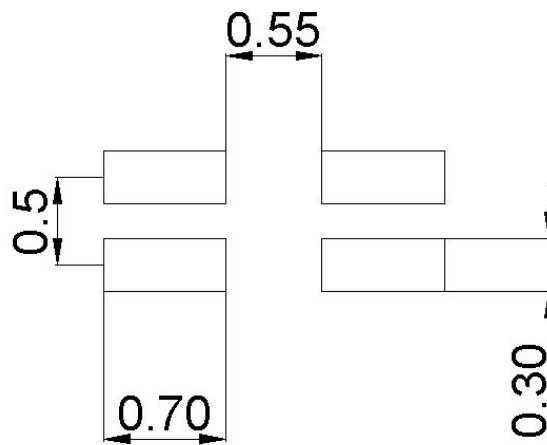
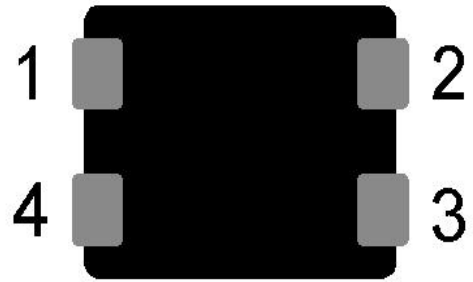
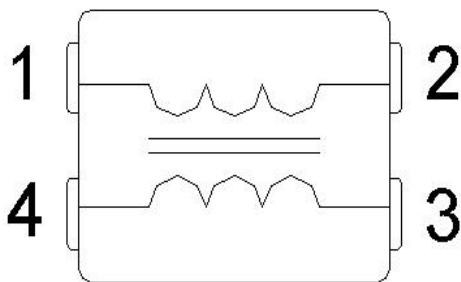

■ TAPE AND REEL SPECIFICATIONS

PAPER CARRIER

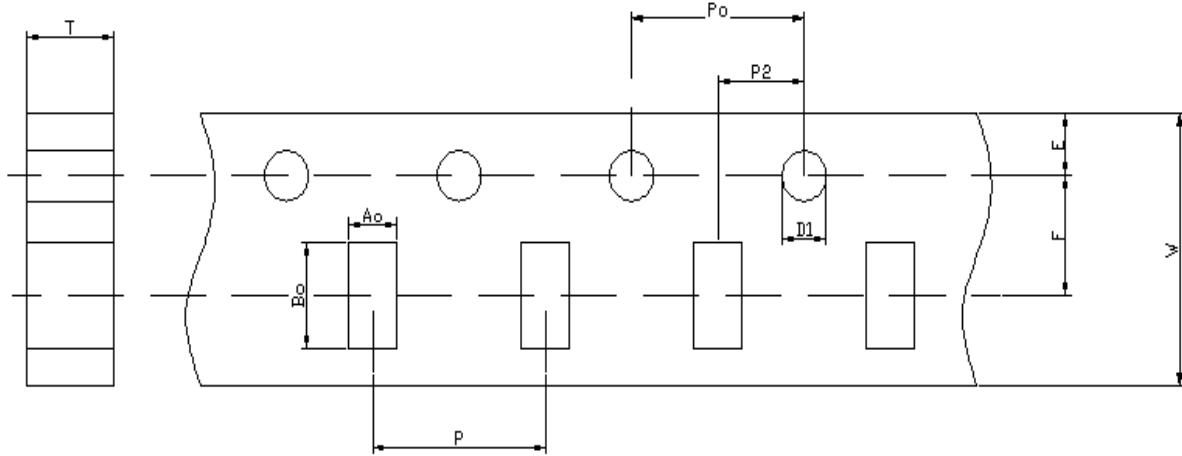

■ TAPING DIMENSIONS

Unit: mm

Symbol	Size	Symbol	Size
W	7.90~8.30	P ₀	4.00 ± 0.10
P	4.00 ± 0.10	P ₂	2.00 ± 0.05
E	1.75 ± 0.10	A ₀	1.30 ± 0.10
F	3.50 ± 0.05	B ₀	1.55 ± 0.10
D1	1.55 ± 0.05	T	1.00 ± 0.10

■ REEL DIMENSIONS

Unit: mm

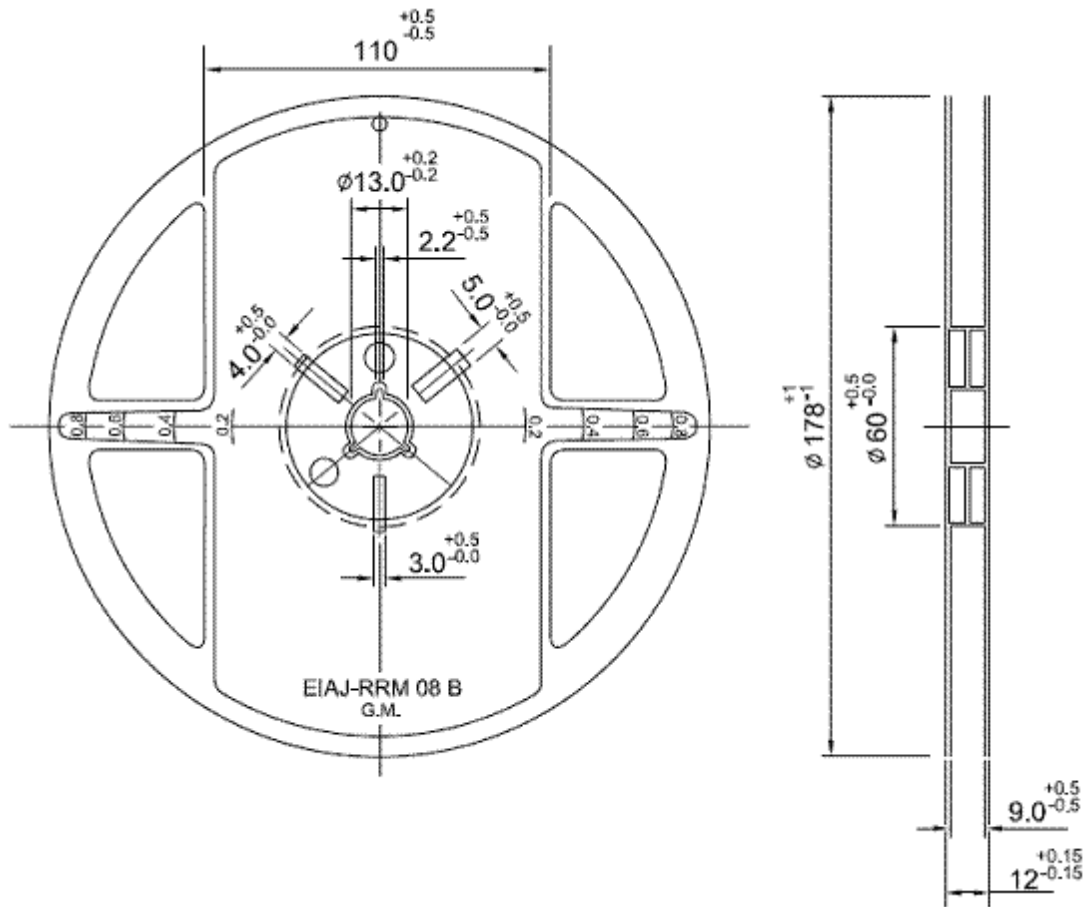

■ STANDARD QUANTITY FOR PACKAGING

PART SIZE (EIA SIZE)	Reel backagging quantity	Inner box
1012 (0405)	4000 pcs/reel	5 reel/inner box

■ RECOMMENDED SOLDERING CONDITIONS

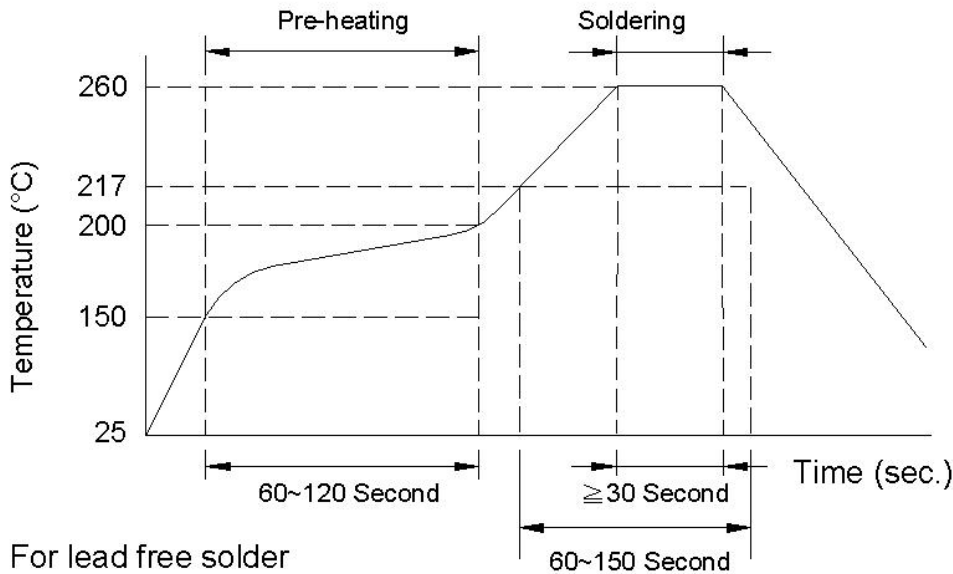

■ RELIABILITY AND TEST CONDITION

Test item	Test condition	Criteria
Temperature Cycle	A. Temperature : -40 ~ +85°C B. Cycle : 100 cycles C. Dwell time : 30minutes Measurement : at ambient temperature 24 hrs after test completion	A. No mechanical damage B. Impedance value should be within ± 20 % of the initial value
Operational Life	A. Temperature : 85°C ± 5°C B. Test time : 1000 hrs C. Apply current : full rated current Measurement : at ambient temperature 24 hrs after test completion	A. No mechanical damage B. Impedance value should be within ± 20 % of the initial value
Biased Humidity	A. Temperature : 40 ± 2°C B. Humidity : 90 ~ 95 % RH C. Test time : 1000 hrs D. Apply current : full rated current Measurement : at ambient temperature 24 hrs after test completion	A. No mechanical damage B. Impedance value should be within ± 20 % of the initial value

Test item	Test condition	Criteria
Resistance to Solder Heat	A. Solder temperature : $260 \pm 5^{\circ}\text{C}$ B. Flux : Rosin C. DIP time : 10 ± 1 sec	A. More than 95 % of terminal electrode should be covered with new solder B. No mechanical damage C. Impedance value should be within ± 20 % of the initial value
Steam Aging Test	A. Temperature : $93 \pm 2^{\circ}\text{C}$ B. Test time : 4 hrs(MCA) Others : 8 hrs C. Solder temperature : $235 \pm 5^{\circ}\text{C}$ D. Flux : Rosin E. DIP time : 5 ± 1 sec	More than 95 % of terminal electrode should be covered with new solder

■ **GENERAL TECHNICAL DATA**

- Operating temperature range : $-40^{\circ}\text{C} \sim +85^{\circ}\text{C}$
- Storage temperature : 40°C Max., 70%RH Max.
- Storage Time: 6 months Max.
- Soldering method: Reflow or Wave Soldering